

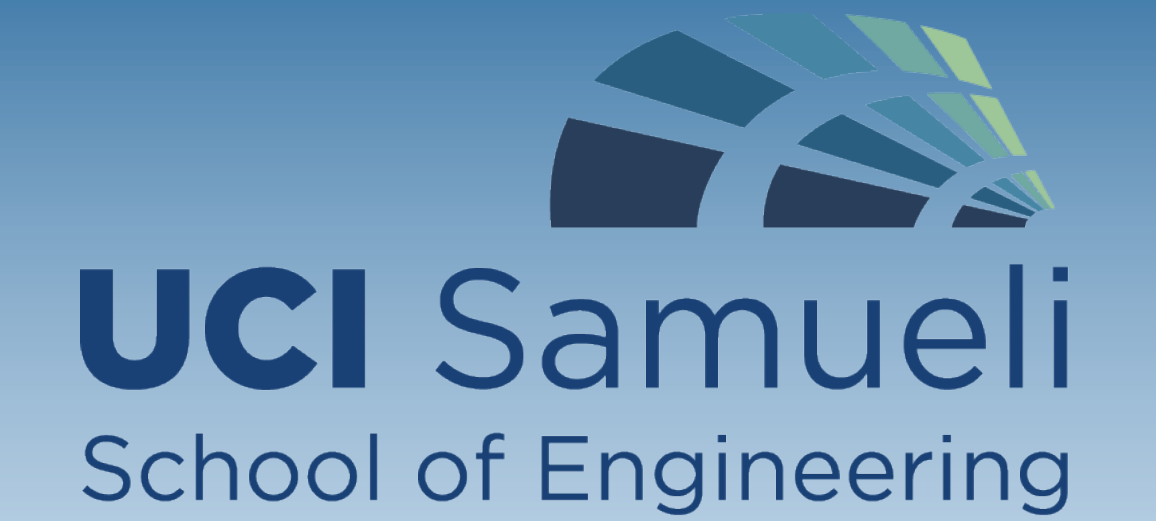

Thermal Orientation Test Bed

Advisors: John LaRue and Khalid Rafique



Background:

Thermal Orientation Test Bed is a joint-research project with Air Force Research Laboratory to design and manufacture an apparatus capable of mimicking conditions in space. The apparatus will test the thermal qualities of heat pipes and satellite components at specific orientations.

Objective:

- Research methods of making ground equipment vacuum compatible
- Accurately simulate torque applied on motor
- Machine gearboxes
- Create a comprehensive Graphic User Interface (GUI) that allows full control over the test table while displaying thermal data readouts
- Design new methods of mounting cold plates, heat pipes and heat sources with minimal heat loss

Goal:

The design, development, fabrication, and testing of a test frame capable of precise orientation adjustments.

Requirements:

- **Environment:** Vacuum (Vacuum rating of 10^{-7} Torr)
- **Minimum Rotation About Primary Axis:** 180°
- **Minimum Rotation About Secondary Axis:** 90°
- **Orientation Accuracy:** 0.1°
- **Max Test Bed Size:** 39.5"x71"x40"
- **Minimum Test Article Size:** 2"x6"x0.08"
- **Maximum Test Article Size:** 24"x24"x30"
- **Maximum Payload Weight:** 200lb

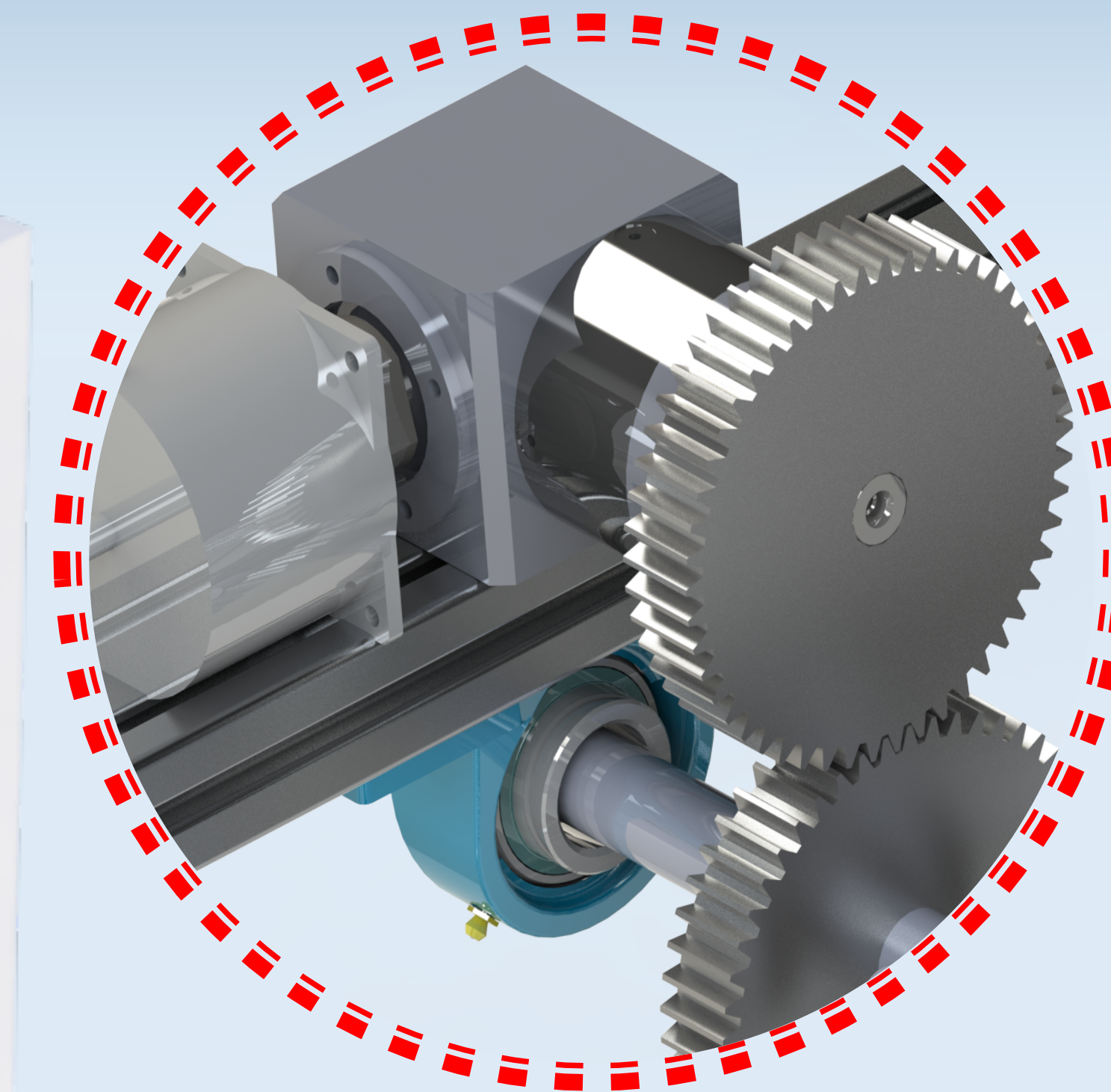
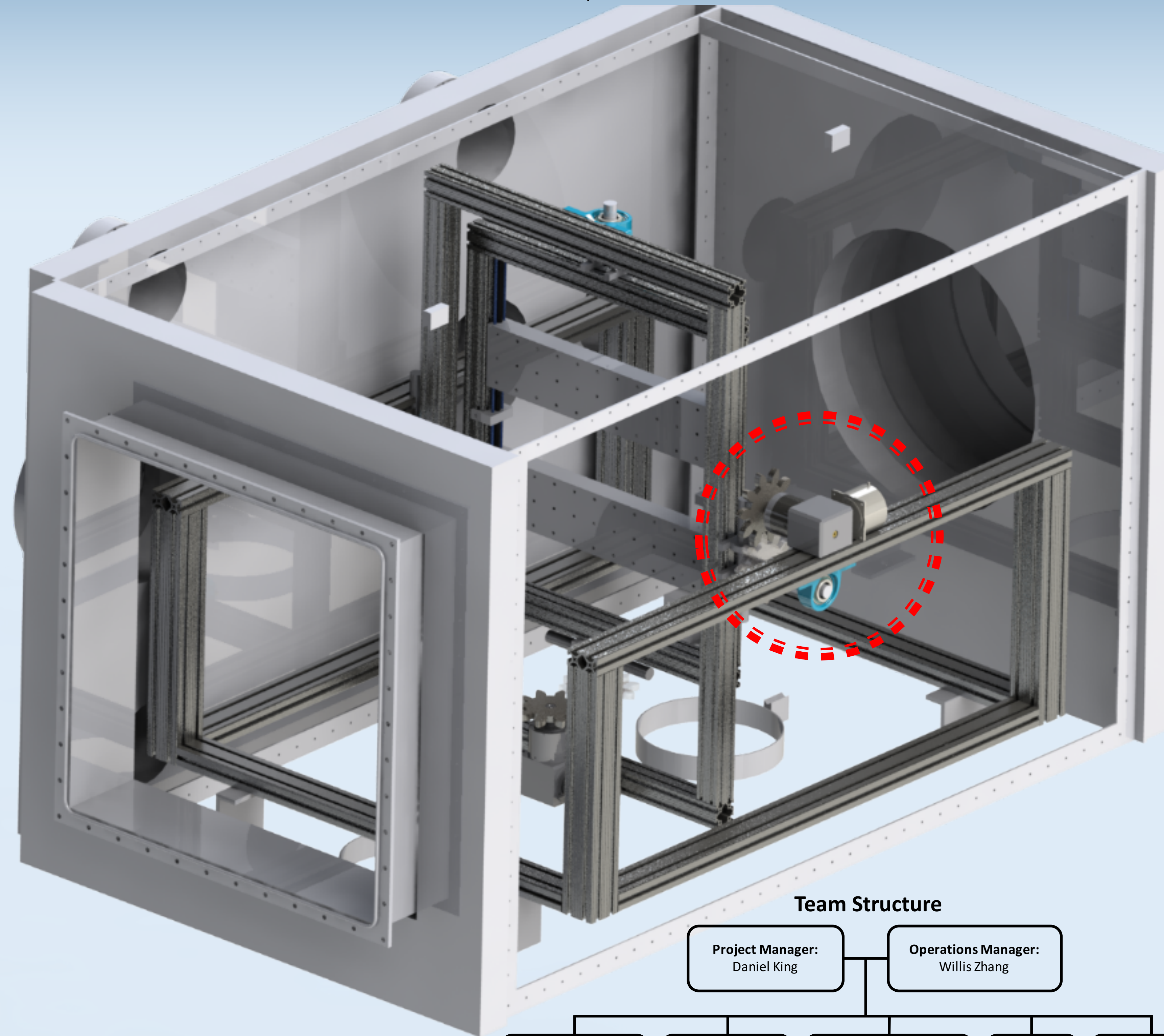

- Nema 42 motors have been selected to provide the most torque possible.
- Gears allow the small motors to provide enough torque for the system payload at lower speeds

Next Steps:

- Continue subsystem detail calculation
- Refine overall design
- Begin fabrication
- Ground testing and calibration
- Develop back-end of LabView Control System

Test bed placed inside vacuum chamber

Team Structure

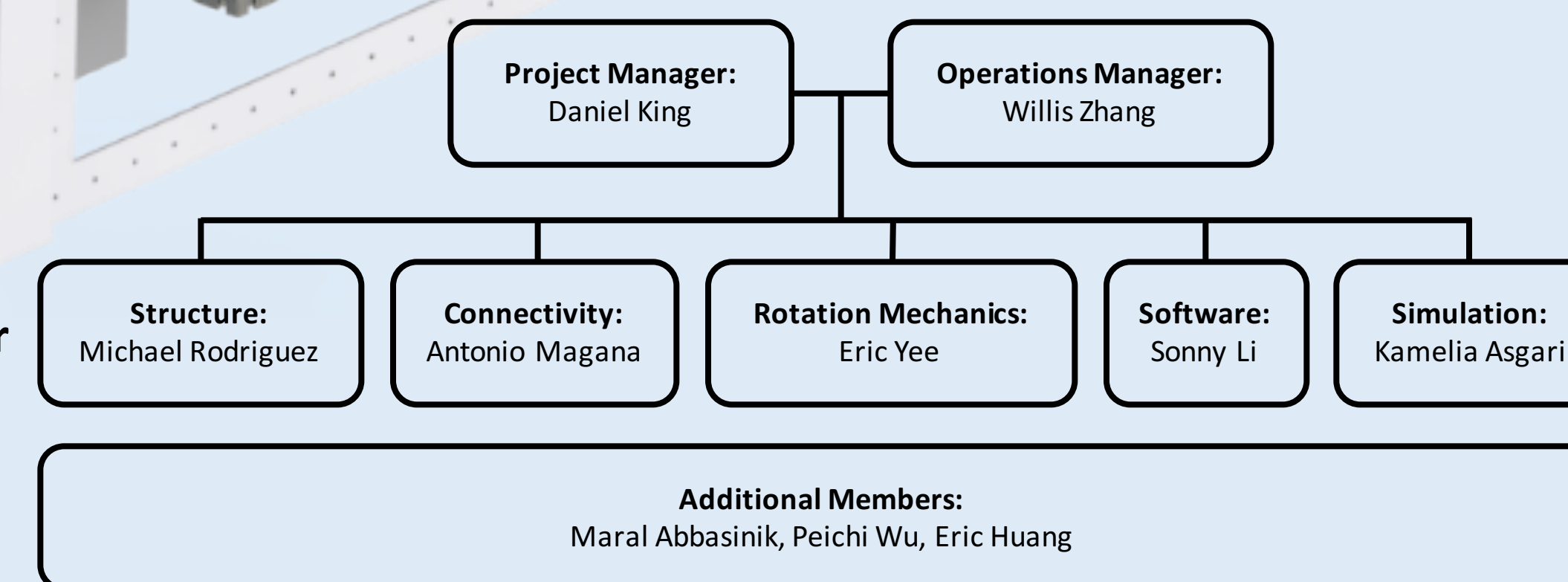

Budget	
Funds	\$11,200
Projected Costs	\$14,875

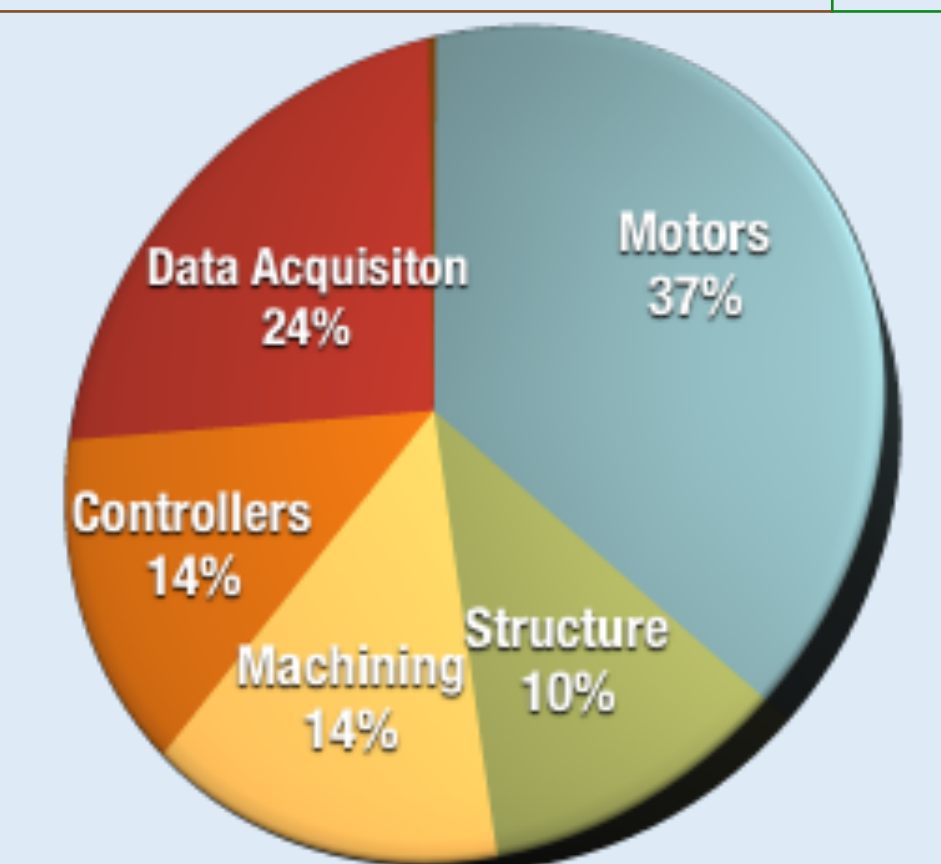

Timeline:



Contact Info:

Professor: krafique@uci.edu
Project Manager: kingd2@uci.edu

